

XE3003

Low-Power Audio ADC

General Description

The XE3003 is an ultra low-power ADC (Analog to Digital Converter) for voice and audio applications.

It includes a microphone supply, programmable preamplifier, 16-bit ADC, Serial Peripheral Interface (SPI), serial audio interface (PCM) as well as the power and clock management for the ADC. The sampling frequency of the ADC can be adjusted from 4 kHz to 48 kHz.

Applications

- Wireless Microphones
- Bluetooth™ headset
- Hands-free telephony
- Digital hearing instruments
- Consumer and multimedia applications
- All battery-operated portable audio devices

Features

- Ultra low-power consumption, below 2 mW
- Low-voltage operation down to 1.8 V
- Single supply voltage
- Adjustable sampling frequency: 4 – 48 kHz
- Digital format: 16 bit 2s complement
- Only a minimum of external components
- Easy interfacing to various DSPs
- Direct connection to microphone
- Various programming options

Quick Reference Data

- Supply voltage range 1.8- 3.6 V
- Typ. current (@3V and fs = 20 kHz) 0.24 mA
- Sampling frequency range 4– 48 kHz
- Typical dynamic range ADC 78 dB
- Typ. power supply rejection 60 dB

Ordering Information

Part	Package	Temperature range
XE3003	TSSOP 16 pins	-20 to 70° C

Table of contents

1	Device Description	3
1.1	Terminal Descriptions XE3003.....	3
2	Functional Description	4
2.1	Device Functions.....	4
2.2	Power-Down Functions	8
3	Serial Communications	9
3.1	Serial Audio Interface	9
3.2	Register Programming	10
3.3	Serial Peripheral Interface - SPI.....	11
4	Specifications	13
4.1	Absolute Maximum Ratings	13
4.2	Recommended Operating Conditions.....	13
4.3	Electrical Characteristics.....	14
5	Application Information	20
5.1	Application Schematics – XE3003	20
6	Register Description	21
6.1	Register Functional Summary.....	21
6.2	Register Definitions	22
7	Mechanical Information	24
7.1	XE3003 package size (TSSOP16).....	24

1 Device Description

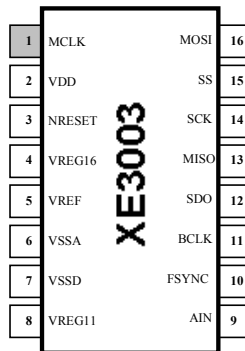

Figure 1: Pin layout of the XE3003

The XE3003 is available in a TSSOP16 package. Detailed information is found in section 7, Mechanical Information.

1.1 Terminal Descriptions XE3003

Terminals		Type ¹	Description
XE3006	Name		
1	MCLK	DI	Master Clock. MCLK derives the internal clock of the ADC.
2	VDD	AI	Digital power supply
3	NRESET	ZI/O	Reset signal generated by the ADC. If required, the reset signal can be applied externally to initialize all the internal ADC registers.
4	VREG16	AO	Regulator voltage 1.6 V. Can be used to supply the microphone.
5	VREF	AO	Reference voltage
6	VSSA	AI	Analog ground
7	VSSD	AI	Digital ground
8	VREG11	AO	ADC Regulated microphone output supply voltage 1.1 V
9	AIN	AI	ADC Analog input signal
10	FSYNC	DI/O	Serial audio interface Frame Synchronization
11	BCLK	DI/O	Serial audio interface Bit Clock
12	SDO	ZO	Serial audio interface Data Output
13	MISO	ZO	SPI Master In Slave Out
14	SCK	DI PD	SPI Serial Clock
15	SS	DI PU	SPI Slave Select
16	MOSI	DI PD	SPI Master Out Slave In

Note: (1) AI = Analog Input AO = Analog Output
 DI = Digital Input DO = Digital Output
 DI/O = Digital In or Out ZO = Hi Impedance or Output
 PU = internal Pull Up PD = internal Pull Down
 ZI/O = Hi impedance In or Out

2 Functional Description

The XE3003 - ADC is typically used as an audio converter for voice and audio applications between a Digital Signal Processor (DSP) and an analogue interface – the microphone.

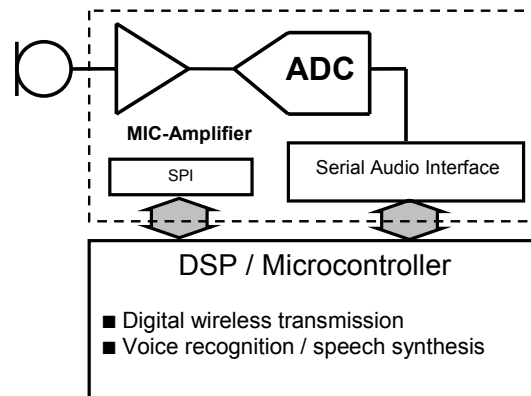

Figure 2: Typical usage of the XE3003

This chapter provides a brief description of the audio ADC features. The configuration of the ADC is defined by programming registers through a serial interface. A detailed description of the registers defining details of the ADC setup can be found in sections 3 and 6. Digital audio samples are passed through the Serial Audio Interface for further processing on the DSP.

2.1 Device Functions

2.1.1 ADC Signal Channel

The ADC channel is a chain of programmable amplifier, band-pass filter, sigma-delta modulator and a decimation filter. The amplifier gain is programmable to 5x (default) and 20x. The band-pass filter has cut-off frequencies proportional to the sampling rate. The sigma-delta modulator operates at a frequency of 64 times the sampling rate. The analog modulator is followed by a digital decimation filter. The digital output data (16 bits, 2's complement format) is made available through the Serial Audio Interface. The format of the Serial Audio interface can be selected through register J.

With the default register settings, the ADC can run at a sampling frequency up to 20 kHz. When used with a sampling frequency higher than 20 kHz, then register C has to be changed.

The whole ADC chain can be powered-down through register I.

For further details about configuring the ADC see section 6 – Register Description.

2.1.2 MIC Input

The programmable pre-amplifier and the microphone bias sources VREG11 or VREG16 are optimized to operate with electret microphones. VREG11 provides a 1.1 V reference voltage. The VREG11 can deliver up to 50 μ A. VREG11 is enabled through control register E. VREG16 is a regulated voltage of typically 1.6 V and can deliver up to 1 mA. VREG16 is always enabled.

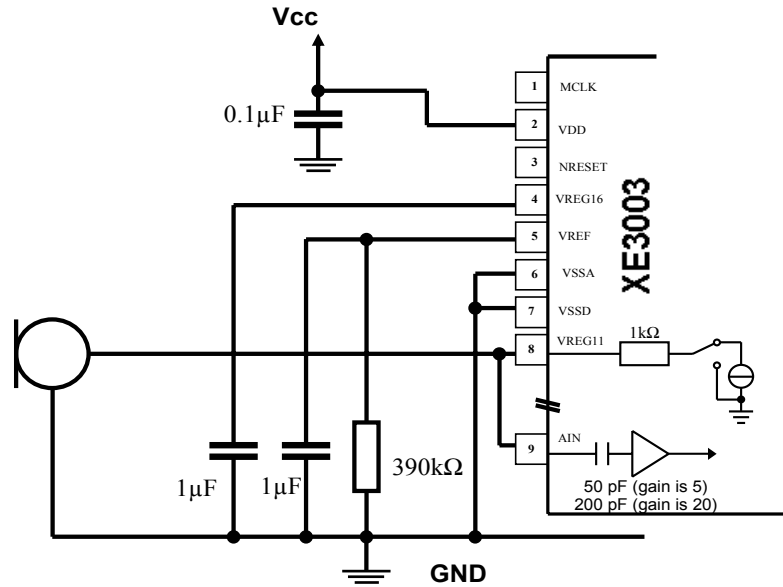

Figure 3: Typical microphone interface (1.1 V / 50 μ A bias through VREG11)

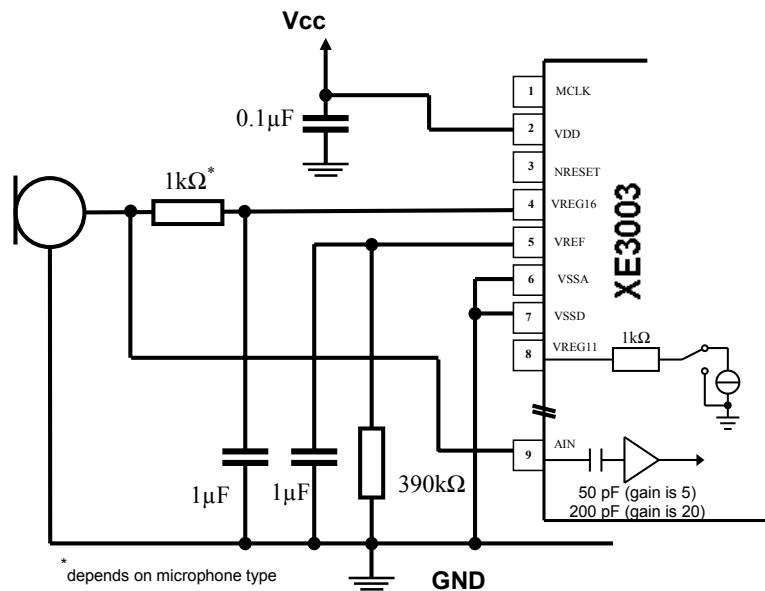

Figure 4: Typical microphone interface (1.6 V / max. 1mA bias through VREG16)

2.1.3 Operating Frequency

A master clock (MCLK) has to be applied to the XE3003. The clock frequency of the signal applied to the MCLK pin may vary between 1.024 MHz minimum and 33.9 MHz maximum. The maximum internal clock signal frequency (MCLK/div_factor) should not exceed 12.288 MHz.

The div_factor can be set by the user in register I to 1,2 or 4. The default value for div_factor is '1'.

2.1.4 Serial Audio Interface

The Serial Audio Interface is a 3-wire interface for communication of audio data. It operates on the bit serial clock BCLK and the frame synchronization signal FSYNC. The sampling frequency of the ADC corresponds to the rate at which the Audio Serial Interface will put out succeeding frames. One frame always corresponds to one sample. One frame always contains 2 channels.

Synchronizing the Serial Audio Interface to the MCLK is recommended. FSYNC and MCLK must have a fixed ratio as defined by the following relation:

$$\text{FSYNC} = \text{Sampling frequency} = \text{frame rate} = \text{MCLK}/(256 \times \text{div_factor}).$$

The pin BCLK defines the time when the data must be shifted out of (pin SDO) the ADC. The number of BCLK periods in one FSYNC period is 32. The user can select to use the first 16 clock cycles (channel 1) or the second 16 clock cycles (channel 2) of BCLK to shift out the data samples.

The table below shows some examples of the relationships between MCLK, BCLK and FSYNC

MCLK	Div_factor	BCLK	FSYNC
2048 kHz	1	256 kHz	8 kHz
8192 kHz	4	256 kHz	8 kHz
5120 kHz	1	640 kHz	20 kHz
22579.2 kHz	2	1411.2 kHz	44.1 kHz

The table below shows the possible functional configurations of the serial audio interface

ADC	supported protocol
master	LFS (long frame sync)
slave	LFS (long frame sync), SFS (short frame sync)

By default the Serial Audio Interface operates in slave, SFS mode. In slave mode the user needs to generate the signals BCLK, FSYNC and supply to the ADC.

In master mode the ADC generates the BCLK and FSYNC signals. In that case the BCLK operates at 32 times the frequency of FSYNC. The ADC master mode can be used with the LFS protocol only.

The register J is used for the different setups of the serial audio interface.

2.1.5 Serial Peripheral Interface - SPI

The SPI interface is used to control register values. It is a serial communications interface that is independent of the rest of the ADC. It allows the device to communicate synchronously with a microprocessor or DSP. The ADC interface only implements a slave controller.

A detailed description can be found in section 3.3.

2.1.6 Start-up and Initialization

The ADC generates its own power on reset signal after a power supply is connected to the VDD pin. The reset signal is made available for the user at the pin NRESET. The rising edge of the NRESET indicates that the startup sequence of the ADC has finished. In most applications the NRESET pin can be left open.

The NRESET signal generated by the ADC is used to initialize the various blocks in the device and guarantees a correct start-up of the circuit. The start-up sequence that is automatically carried out upon power-up of the device is listed below and illustrated in Figure 5.

- 1) NRESET is low (0V) when the device is not powered and remains low for a short time when VDD (upper curve in Figure 5) is applied. The low state sustains while VDD, VREG16, VREF are stabilizing.
- 2) As soon as the MCLK signal is present, a counter is activated that counts 2^{21} periods of the MCLK. After this moment the NRESET is in the high state (VDD).

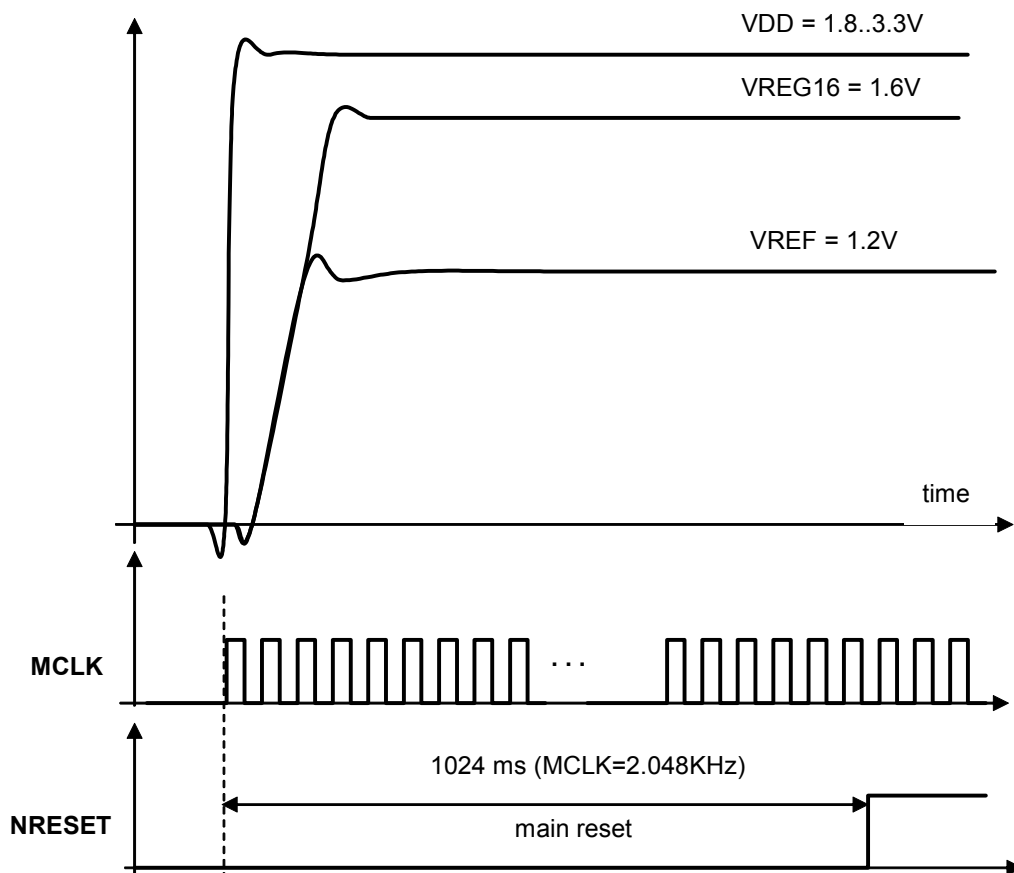

Figure 5: Startup sequence and NRESET signal after power-on.

The user can use the NRESET pin in 3 different ways and combinations:

- 1) Leave the NRESET pin not connected. In this case the ADC will startup as described in figure 5.
- 2) Use the NRESET pin as an output to indicate, to e.g. a microcontroller, that the ADC finished its power up sequence and that the ADC is ready to operate.
- 3) Use the NRESET pin to force a re-initialization of the registers to their default values. In this case the user has to force the NRESET to 0V for at least 32 periods of the MCLK. The circuit which forces the NRESET to 0V should be able to sink at least 50 μ A.

Figure 6 shows the block diagram of the CODEC reset.

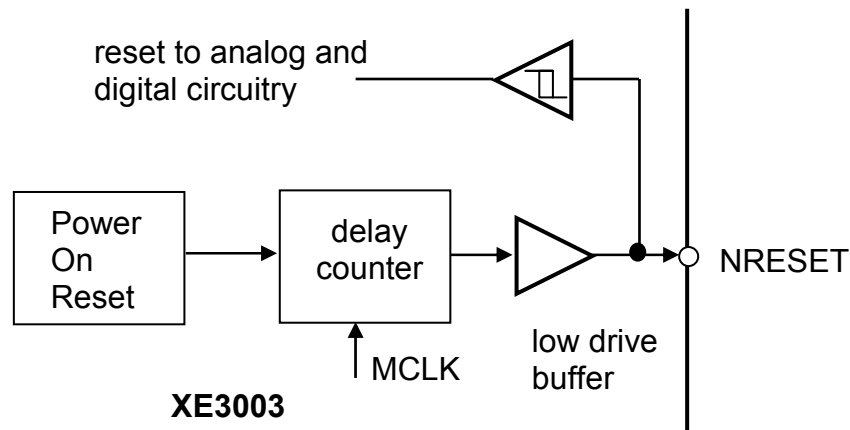

Figure 6: ADC reset circuitry

2.2 Power-Down Functions

2.2.1 Software Power-Down

Register I allows for the selective power down of the ADC signal channel. The wake-up time, after powering down the device is typically 200 μ s. The maximum standby current is 96 μ A, depending highly upon the Master clock (MCLK), see 4.3.4.2 Low Power Modes.

2.2.2 Hardware Power-Down

The device has no power-down pin. However, by holding down (0 V) the NRESET pin (resetting the device) as well as the pins MCLK, BCLK and FSYNC, the power consumption will reach the standby current of typically 16 μ A. Use the standard procedure for power up (see start-up and initialization procedure) after a hardware power down the registers setup procedure must be applied.

3 Serial Communications

3.1 Serial Audio Interface

The Serial Audio Interface is a 3-wire interface for communication of the audio data. The 3 terminals are listed below:

- BCLK: Bit serial clock, one clock cycle corresponds to one data bit transmitted or received.
- FSYNC: Frame Synchronization. This signal indicates the start of a data word. The frequency of the FSYNC corresponds to the sample frequency of the ADC.
- SDO: Serial Data Out, data received from ADC and sent to external device.

The clock (BCLK) and synchronization (FSYNC) signals are used for sending the audio data. The synchronization signal FSYNC must have a fixed ratio with the master clock signal MCLK.

The Serial Audio Interface supports two formats that are commonly used for audio/voice ADCs and that are referred to as SFS (Short Frame Synchronization) and LFS (Long Frame Synchronization). Data can be transmitted in 2 channels. Which channel is selected depends on the programmed values in the registers. The two interface protocols are shown below.

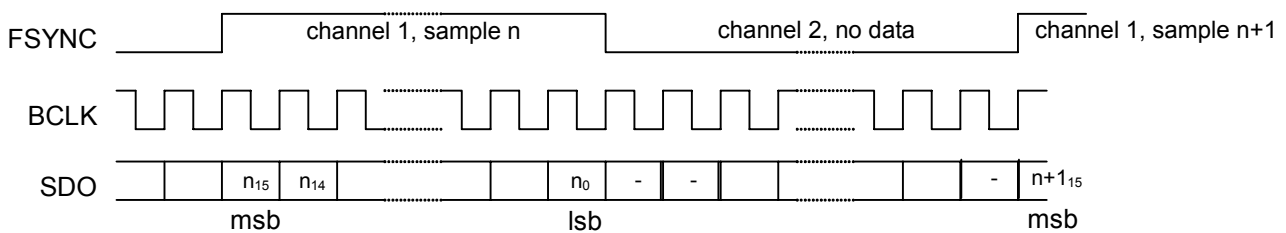

Figure 7: Audio interface timing LFS mode, channel 1

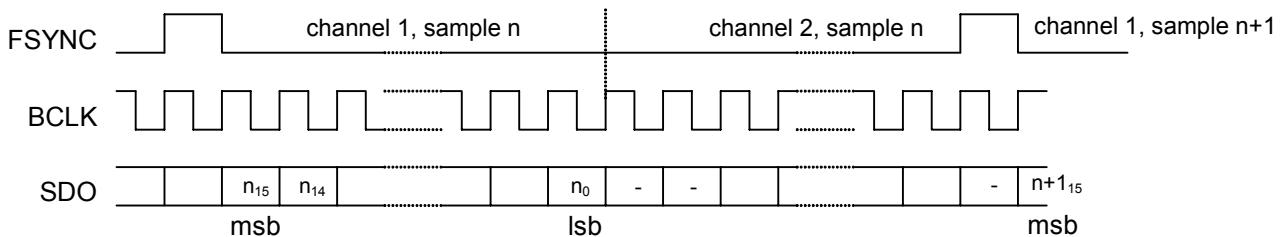

Figure 8: Audio interface timing in SFS mode, channel 1

SDO data will change on the rising edge of the BCLK. The SDO data should be read on the falling edge of the BCLK. Each rising edge of the FSYNC indicates the start of a new sample.

3.1.1 LFS optimization

For receiving, 32 clock cycles in one frame is always required (figure 7 and 8). This is even the case when only 16 bits have to be received. In most cases this can be easily handled with a DSP and microcontroller.

If the user wants to send a minimum of BLCK cycles, it is possible to shorten channel 1 (channel 2 can not be shortened).

In the LFS mode the possibility exists to shorten the number of BLCK cycles to 17 instead of 32. In this case the data is received in channel 2. Channel 1 is shortened to one BLCK cycle only.

The figure 9 shows this special LFS mode.

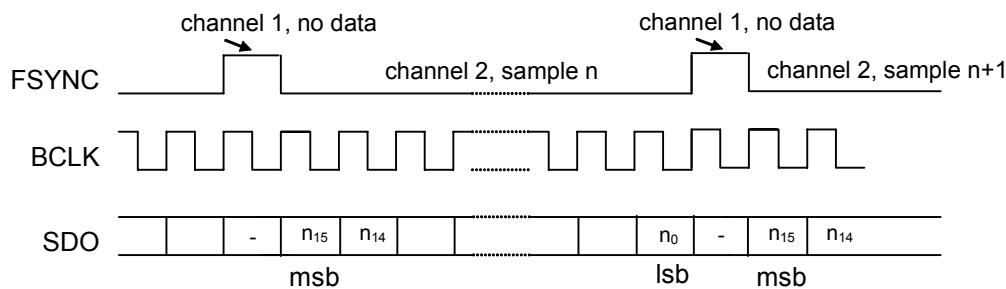

Figure 9: Audio interface timing in LFS mode, 17 BLCK cycles, channel 2

3.2 Register Programming

The control registers define the configuration of the ADC and define the various modes of operation. During power-up, all registers will be configured with default values. The control register set consists of 9 registers. A detailed description is provided in section 6.

The control registers can be changed in the two following ways:

1. Logic values at SPI pins during power-up

There are 3 bits inside the registers which are configured depending on the logic values of the pins SS, SCK and MOSI during the power up startup sequence as described in section 2.1.6.

Value at power up	Influenced bits of registers	comments
SS = 1	Register I(0)=0	MCLKDIV division by 1
SS = 0	Register I(0)=1	MCLKDIV division by 2
SCK = 0	Register J(0)=1	SFS protocol
SCK = 1	Register J(0)=0	LFS protocol
MOSI = 0	Register E(2) = 0	preamplifier gain x5
MOSI = 1	Register E(2) = 1	preamplifier gain x20

Using the SPI pins at startup, the user is able to configure the ADC in the corresponding setups without reprogramming through the SPI interface and protocol. In best case the SPI interface can then be completely omitted and the 3 SPI pins can be fixed to '0' or '1'.

2. Programming through SPI interface after power-up

Once the device has been powered up, the configuration registers can be modified at all times (also when the device is active) through the SPI interface.

The following section describes the SPI protocol which is required to change the control registers from their default values.

3.3 Serial Peripheral Interface - SPI

The Serial Peripheral Interface (SPI) allows the device to communicate synchronously with other devices such as a microprocessor or a DSP. The ADC interface only implements a slave controller. This section describes the communication from master (e.g. DSP) to slave (ADC pin MOSI) and from slave (ADC pin MISO) to a master (e.g. DSP).

Four lines are used to transmit data between the slave and master:

- MOSI (Master Out, Slave In) data from master to slave, synchronous with the SPI clock (SCK).
- MISO (Master In, Slave Out) data from slave to master, synchronous with the SPI clock (SCK).
- SCK (Serial Clock) synchronizes the data bits of MOSI and MISO.
- SS (Slave Select) Slave devices are selected by activating SS.

3.3.1 Protocol

During SPI communication, data is simultaneously transmitted and received.

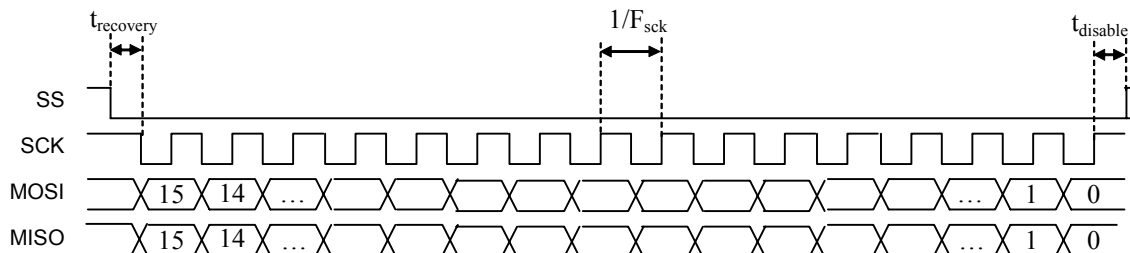

Figure 10: SPI signal timing

The master puts data on the MOSI line on the falling edge of SCK; the slave reads the data on the rising edge of SCK. The slave puts data on the MISO line on the falling edge of SCK; the master reads the data on the rising edge of SCK. Transmission in either direction is by 2 bytes with MSB first.

The SS pin should be kept low during the whole transfer of data.

There are three timing constraints:

- Recovery time (t_{recovery}) between the falling edge of SS and the falling edge of SCK.
- Disable time (t_{disable}) between the last rising edge of SCK and the rising edge of SS.
- SCK frequency (F_{SCK})

Delay	Min	Max	Unit	Comments
t_{recover}	125	-	ns	T_{master} = clock period of the master clock MCLK F_{master} = frequency of the master clock MCLK
t_{disable}	$2 \times T_{\text{master}}$	-	ns	
F_{SCK}		$0.5 \times F_{\text{master}}$	Hz	

3.3.2 SPI Interface Modes

There are two SPI modes: read and write.

3.3.2.1 Read Mode

Read communication always takes place in pairs of bytes. A read request of 2 bytes is sent on the MOSI line. The content of the addressed register, one byte, is dumped on the MISO line during the transmission of the second byte on the MOSI. The formats of one byte are the following:

bit	7	6	5	4	3	2	1	0	
mosi	1	1	0	msb			A (4:0)		lsb

bit	7	6	5	4	3	2	1	0
miso	msb			D(7:0)				lsb

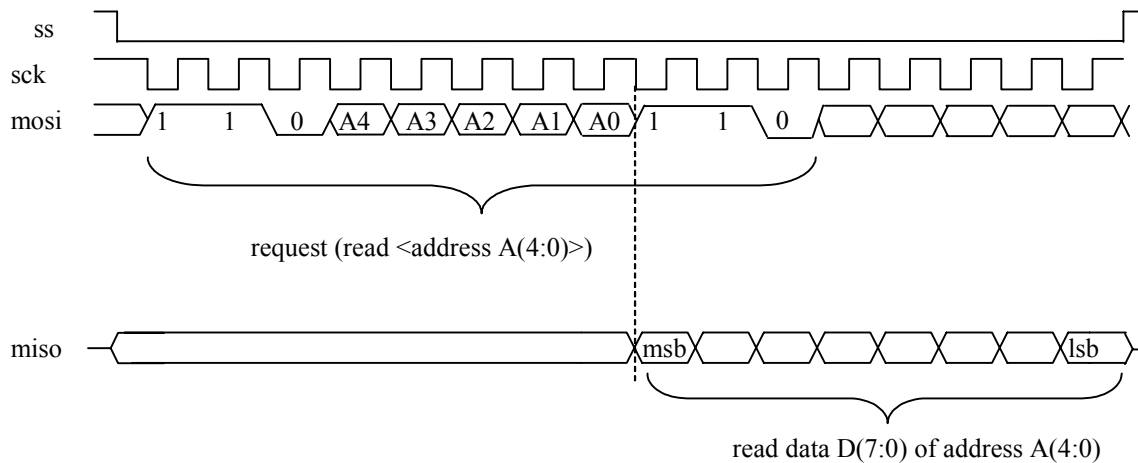

Figure 11: SPI signal timing in read mode

3.3.2.2 Write Mode

Write communication always takes place in pairs of bytes. The format of the 2 bytes is:

Bit	7	6	5	4	3	2	1	0	
mosi	1	0	0	msb			A(4:0)		lsb

Bit	7	6	5	4	3	2	1	0
mosi	msb			D(7:0)				lsb

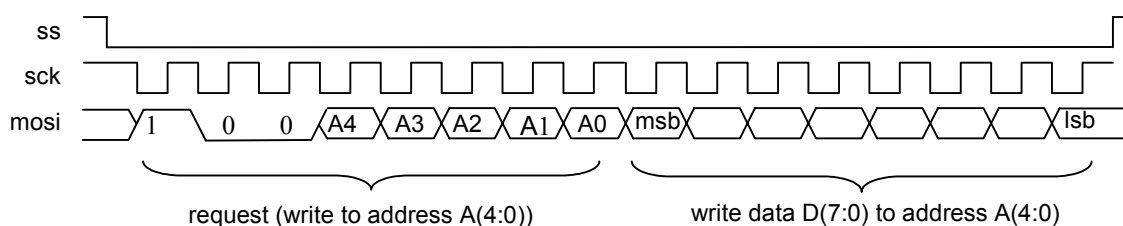

Figure 12: SPI signal timing in write mode

4 Specifications

4.1 Absolute Maximum Ratings

Stresses above those listed in the following table may cause permanent failure. Exposure to absolute ratings for extended periods may affect device reliability.

The values are in accordance with the Absolute Maximum Rating System (IEC 134).

All voltages are referenced to ground (VSSA and VSSD).

Analog and digital grounds are equal (VSSA = VSSD).

Symbol	Parameter	Conditions	Min	Max	Unit
VDD	Supply voltage		-0.3	3.65	V
Tstg	Storage temperature		-65	150	°C
TA	Operating free-air temperature, TA		-20	70	°C
Ves	Electrostatic discharge protection	1)		500	V
I _l us	Static latchup current	2)	10	98	mA
V _l ud	Dynamic latchup voltage	2)		50	V

1) Tested according MIL883C Method 3015.6, class JEDEC 1B (Standardized Human Body Model: 100 pF, 1500 Ω, 3 pulses, protection related to substrate).

2) Static and dynamic latchup values are valid at 27 °C.

4.2 Recommended Operating Conditions

All voltages referenced to ground (VSSA and VSSD).

	Min	Typ	Max	Unit
Supply voltage, VDD	1.8	3.0	3.6	V
Analog signal peak-to-peak input voltage, AIN (gain = 20x)			65	mV
Analog signal peak-to-peak input voltage, AIN (gain = 5x)			270	mV
Differential output load resistance	16	32		Ohm
Master clock frequency	1.024		33	MHz
ADC conversion rate		20	48	kHz
Operating free-air temperature, TA	-20		70	°C

4.3 Electrical Characteristics

The operating conditions in this section are: VDD = 3.0 V, T = 25°C.

4.3.1 Digital Inputs and Outputs, FSYNC = 20 kHz, output not loaded

	Parameter	Test Conditions	Min	Typ	Max	Unit
VOH	High-level output voltage, DOUT	IO = -360uA	2.4		VDD+0.5	V
VOL	Low-level output voltage, DOUT	IO = 2mA	VSSD-0.5		0.4	V
IiH	High-level input current, any digital input	VIH = 3.3 V			10	uA
IiL	Low-level input current, any digital input	VIL = 0.6 V			10	uA
Ci	Input capacitance				10	pF
Co	Output capacitance				10	pF

4.3.2 ADC Dynamic Performance, FSYNC = 20 kHz

	Parameter	Test Conditions	Min	Typ	Max	Unit
SNR	Signal-to-noise ratio	Pre-amp gain = 5x Vin=250mV (full scale)	72	78		dB
THD	Total harmonic distortion	¼ full scale		0.5		%
Flo	Low cut-off frequency (-3 dB), See Note 1	FSYNC = 20 kHz	60	70	80	Hz
Fhi	High cut-off frequency (-3 dB), See Note 2	FSYNC = 20 kHz		10		kHz
GD	Group delay	FSYNC = 20 kHz			150	us

Note 1) Flo is proportional to FSYNC

Note 2) Fhi equals FSYNC/2

4.3.3 ADC Channel Characteristics, FSYNC = 20 kHz

	Parameter	Test Conditions	Min	Typ	Max	Unit
Vipp	Peak-to-peak input voltage (single ended)	Pre-amp gain = 5x			270	mV
		Pre-amp gain = 20x			65	
Vneq	Equivalent input noise	A-weighted, 100 Hz-10 kHz pre-amp gain = 5x			20	µV rms
		A-weighted, 100 Hz-10 kHz pre-amp gain = 20x			5	
	Dynamic range	Pre-amp gain = 5x Vin=250mV (full scale)	72	78		dB
PSRR	Power supply rejection ratio, input referred	Up to 1 kHz		60		dB
Cin	Input capacitor	Preamp-gain = 5x		50		pF
		Preamp gain = 20x		200		
Rin	Input resistance VIN – VSSA		1			MOhm
Eg	gain error	VDD 1.8-3.3V		+/- 0.1		[%]
	offset error	VDD 1.8-3.3V		-60		LSB
	input noise	VDD 1.8-3.3V		6.7		LSB
INL	Integral non linearity	VDD 1.8-3.3V		+/- 5		LSB
DNL	Differential non linearity	VDD 1.8-3.3V		+/- 0.1		LSB

4.3.4 Power Supply

4.3.4.1 Regulated supply characteristics @ T = 25°C

	Parameter	Test Conditions	Min	Typ	Max	Unit
VREF	reference Voltage	1μF capacitor 390kΩ resistor		1.2		V
VREG11	regulated Voltage 1.1V			1.1		V
I_vreg11	available current			35	50	μA
R_vreg11	output impedance			1	1.5	kOhm
VREG16	regulated Voltage 1.6V	1μF capacitor	1.5	1.6		V
I_vreg16	available output current				1	mA
VREF PSRR	power supply rejection ratio, input referred	up to 1 kHz		60		dB
VREG11 PSRR	power supply rejection ratio, input referred	up to 1 kHz		60		dB
VREG16 PSRR	power supply rejection ratio, input referred	up to 1 kHz		40		dB

4.3.4.2 Low power mode

Stand-by mode @ VDD = 3.0V, T = 25°C

	Parameter	Test Conditions	Min	Typ	Max	Unit
Istb1	Supply current in standby mode	ADC off, MCLK = 5 MHz,		28	56	μA
Istb2	Supply current in standby mode	ADC off, MCLK = 12.2880 MHz		48	96	μA
Istb3	Supply current in standby mode	NRESET mode MCLK = 0		20	40	μA

Stand-by mode @ VDD = 1.8V, T = 25°C

	Parameter	Test Conditions	Min	Typ	Max	Unit
Istb1	Supply current in standby mode	ADC off, MCLK = 5 MHz,		25	50	μA
Istb2	Supply current in standby mode	ADC off, MCLK = 12.2880 MHz		31	62	μA
Istb3	Supply current in standby mode	NRESET mode MCLK = 0		16	32	μA

4.3.4.3 Normal operation

Normal operations @ VDD = 3.0V, FSYNC = 20 kHz, T = 25°C, Register C(7:0) = 0xF0

	Parameter	Test Conditions	Min	Typ	Max	Unit
IADC	Supply current ADC	ADC on FSYNC = 20 kHz		240	480	μA

Normal operations @ VDD = 3.0V, FSYNC = 48 kHz, T = 25°C, Register C(7:0) = 0xC4

	Parameter	Test Conditions	Min	Typ	Max	Unit
IADC	Supply current ADC	ADC on FSYNC = 48 kHz		600	1200	μA

Normal operations @ VDD = 1.8V, FSYNC = 20 kHz, T = 25°C, Register C(7:0) = 0xF0

	Parameter	Test Conditions	Min	Typ	Max	Unit
IADC	Supply current ADC	ADC on FSYNC = 20 kHz		200	400	μA

Normal operations @ VDD = 1.8V, FSYNC = 48 kHz, T = 25°C, Register C(7:0) = 0xC4

	Parameter	Test Conditions	Min	Typ	Max	Unit
IADC	Supply current ADC	ADC on FSYNC = 48 kHz		505	1010	μA

4.3.5 Timing Requirements of serial audio interface

Ref. No. *	Characteristics	Test Conditions	Min	Typ	Max	Unit	
1	Master Clock Frequency for MCLK = 1/ T	C _{Load} = 10pF	1024	5.12	33	MHz	
1	MCLK Duty Cycle		45		55	%	
2	Rise Time for All Digital Signals				10	ns	
3	Fall Time for All Digital Signals				10	ns	
4	Hold time BCLK or FSYNC high after MCLK low		T/4			ns	
5	Setup time BCLK or FSYNC high to MCLK low		T/4			ns	
6	Hold time BCLK or FSYNC low after MCLK low		T/4			ns	
7	Setup time BCLK or FSYNC low to MCLK low		T/4			ns	
8	Bit Clock Frequency for BCLK = 1 / T _{BCLK}				32xFSYNC	MCLK/2	MHz
9	Setup time data input SDI to BCLK low			not applicable			ns
10	Hold time data input SDI after BCLK low			not applicable			ns
11	Delay time SDO valid after BCLK high					T _{BCLK} /4	ns
12	Setup time data input FSYNC to BCLK low		T _{BCLK} /4				ns
13	Hold time data input FSYNC after BCLK low	T _{BCLK} /4				ns	

*see figure 13,14 for LFS and 15, 16 for SFS mode

4.3.5.1 Timing diagram of the serial audio interface – LFS mode

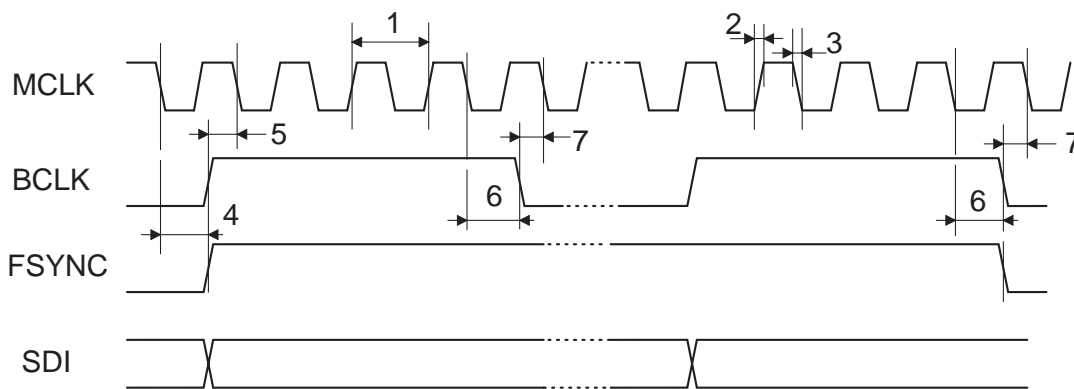

Figure 13: LFS mode, timing diagram

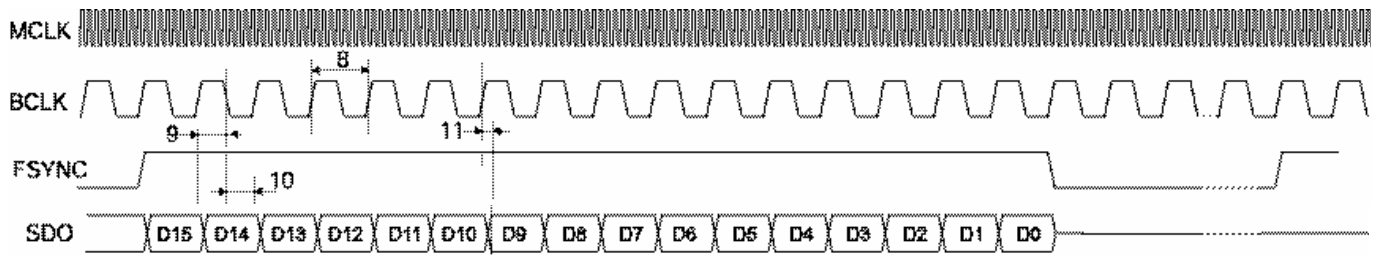

Figure 14: LFS mode, zoom timing diagram

4.3.5.2 Timing diagram of the serial audio interface – SFS mode

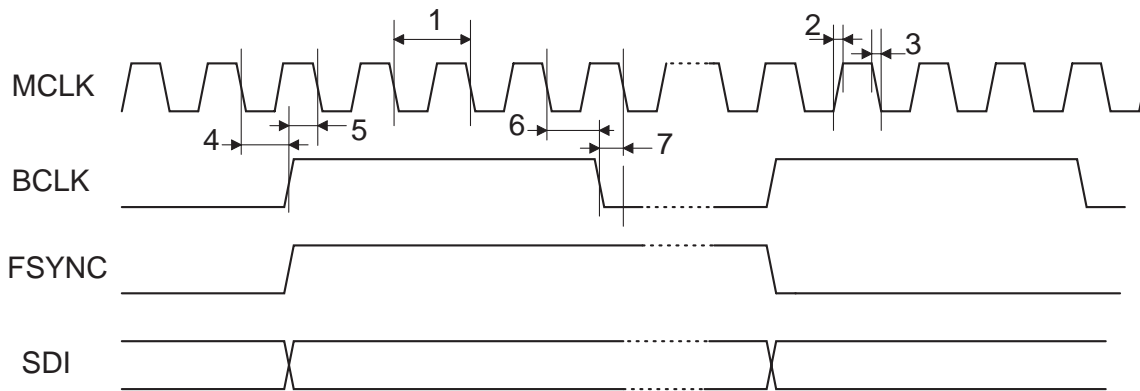

Figure 15: SFS mode, timing diagram

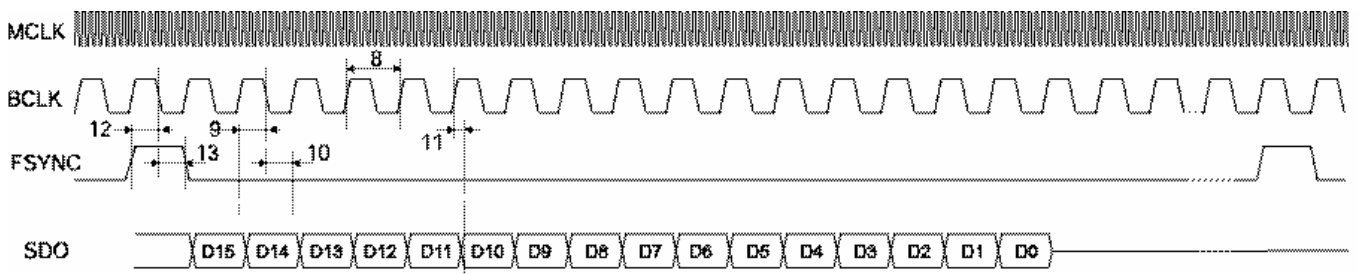

Figure 16: SFS mode, zoom timing diagram

4.3.6 Timing Requirements of the Serial Peripheral Interface

Ref. No. *	Characteristics	Test Conditions	Min	Typ	Max	Unit
1	Serial Clock Frequency for SCK = 1 / T _{SCK}	C _{Load} = 10pF			MCLK/2	MHz
1	MCLK Duty Cycle		45		55	%
2	Recovery Time		125			ns
3	Disable Time		2T			ns
4	Setup time MISO valid to SCK high		T _{SCK} /4			ns
5	Hold time MISO valid after SCK high		T _{SCK} /4			ns
6	Delay time MOSI valid after SCK low		T _{SCK} /4			ns

* see figure 17

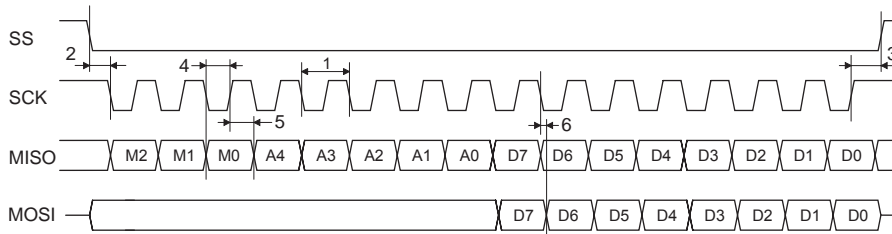

Figure 17: Serial Peripheral Interface timing

5 Application Information

5.1 Application Schematics – XE3003

5.1.1 Typical Application schematic - microphone bias through VREG11 (1.1 V / 50 μ A)

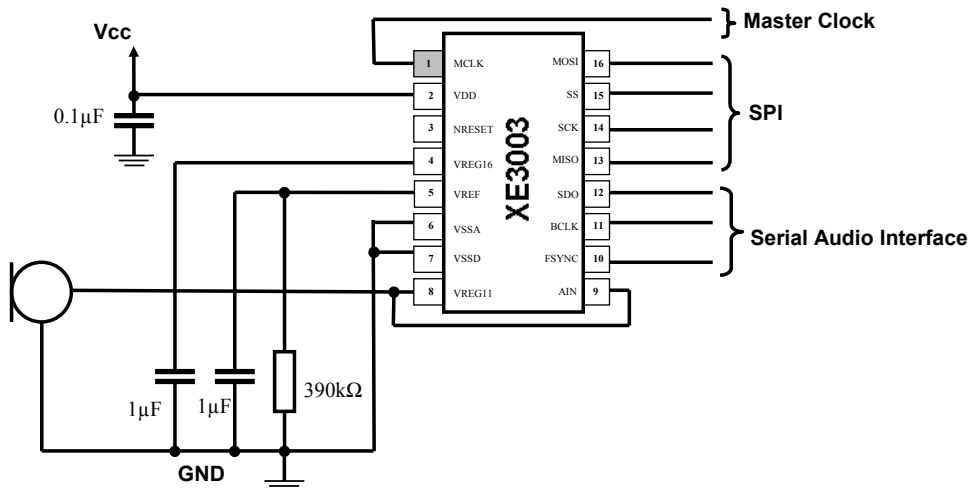
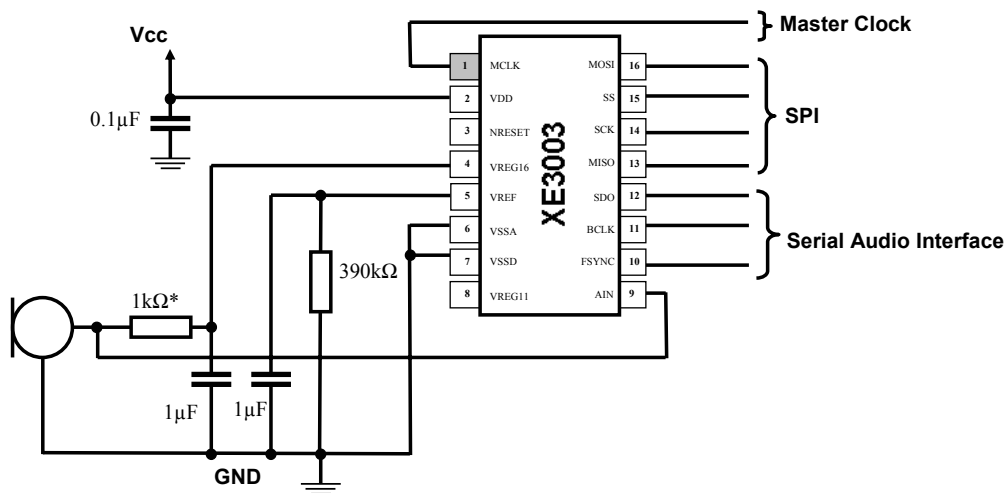

Figure 18: Typical Application with microphone bias through VREG11 (1.1V / 50 μ A)

5.1.2 Typical Application schematic - microphone bias through VREG16 (1.6 V)



* depends on microphone type

Figure 19: Typical Application with microphone bias through VREG16 (1.6V / max. 1mA)

6 Register Description

6.1 Register Functional Summary

The following registers can be programmed by the SPI to configure the operation modes. See also section 3.2 Register Programming.

Name	Description
Register C	ADC current setting. The data in this register has the following functions: <ul style="list-style-type: none"> • Adjust the ADC current for FSYNC > 20kHz • 0xF0 for FSYNC ≤ 20 kHz, 0xC4 for FSYNC > 20 kHz.
Register E	Analog Input. The data in this register has the following functions: <ul style="list-style-type: none"> • Enable/disable microphone bias source of 1.1 V • Gain setting of pre-amplifier.
Register I	Function enable and clock division. The data in this register has the following functions: <ul style="list-style-type: none"> • Enable/disable ADC channel (pre-amplifier, ADC, decimation filter) • Division of master clock
Register J	Audio Interface Configuration. The data in this register has the following functions: <ul style="list-style-type: none"> • Channel select receive • Select master / slave mode • Output impedance • Channel select transmit • Select short / long frame sync

6.2 Register Definitions

The complete register setup consists of 11 registers of 8 bits each, as shown in the table below. All registers are preconfigured with the default values and do not have to be programmed by the user if no changes in the setup are required.

The registers C, E, I and J can be used to configure the XE3003 differently than the default setup.

Register	Address (hex)	Name	Default value (hex)
A	0x00	Reserved	0x48
B	0x01	Reserved	0x8F
C	0x02	ADC current	0xF0
D	0x03	Reserved	0x00
E	0x04	Analog input	0x08/0x0C
F	0x05	Reserved	0x82
G	0x06	Reserved	0x00
H	0x07	Reserved	0x00
I	0x08	Block on/off and clock division	0x00/0x01
J	0x09	Audio interface configuration	0x25/0x24
K	0x0A	Reserved	0x00

Register C (7:0) address 0x02	ADC current	Default value: 0xF0	Description
7:0	ADC current	0xF0	0xF0 for FSYNC ≤ 20 kHz, 0xC4 for FSYNC > 20 kHz.

Register E (7:0) address 0x04	ADC input	Default value 0x08/0x0C	Description
7	VMIC_EN	0	Generation of the microphone supply at pin VREG11: 1: enables VREG11 0: disables VREG11
6:3	reserved	0001	reserved
2	PREAMP_GAIN	0 or 1	Gain of preamplifier: 0: 5x (280 mV pp) 1: 20x (70 mV pp)
1:0	reserved	00	The default is depending on the logic value of the pin MOSI during startup (see section 3.2) MOSI=0, default will be set to 0 MOSI=1, default will be set to 1 reserved

Register I (7:0) address 0x08	block on/off and clock division	Default value 0x00/0x01	Description
7:4	reserved	0000	reserved
3		0	reserved
2	EN_ADC	0	0: enable 1: disable AD converter (Preamp + ADC + decimator)
1:0	MCLKDIV	00 or 01	Division factor of the master clock: 00: 1 01: 2 10: reserved 11: 4 The default is depending on the logic value of the pin SS during startup (see section 3.2 Register Programming) SS=0, default will be set to 1 SS=1, default will be set to 0

Register J (7:0) address 0x09	Audio interface configuration	Default value 0x25/ 0x24	Description
7	reserved	0	reserved
6	RX_FIRST_ SECOND	0	0: Receive audio data in the first 16-bit channel after the frame synchronization. 1: Receive audio data in the second 16-bit channel after the frame synchronization.
5	reserved	1	reserved
4	MASTER	0	1: enable audio interface in master mode (only for LFS) 0: enable audio interface in slave mode (LFS or SFS)
3	SDO_HI_EN	0	0: SDO is continuously in output mode for both data channels. 1: SDO is in output mode when transmitting a channel with data (J(2) or J(1)=1). It is switched automatically into high-impedance state when a channel with no data is transmitted (J(2) or J(1)=0).
2	TX_FIRST	1	1: transmit the audio data in the first 16-bit channel after the frame synchronization. 0: do no transmit data in the first channel.
1	TX_SECOND	0	1: transmit the audio data in the second 16-bit channel after the frame synchronization. 0: do no transmit data in the second channel.
0	PROTOCOL	0 or 1	1: Short Frame Synchronization mode (slave mode). 0: Long Frame Synchronization mode (mode master or slave). The default is depending on the logic value of the pin SCK during startup (see section 3.2 Register Programming) SCK=0, default will be set to 1 SCK=1, default will be set to 0

7 Mechanical Information

7.1 XE3003 package size (TSSOP16)

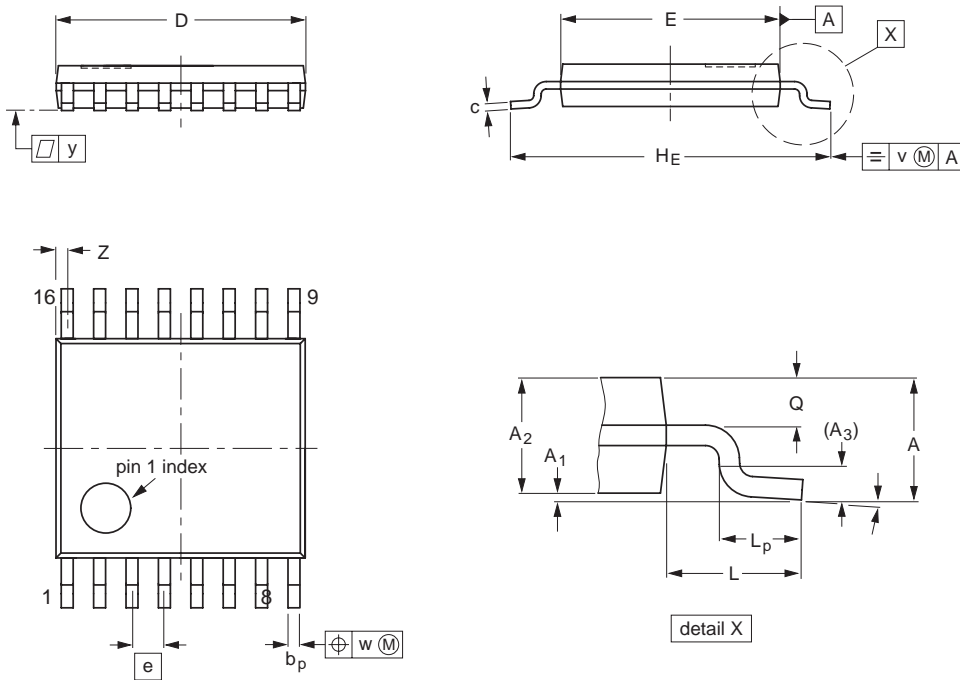

DIMENSIONS (mm are the original diransions)

UNIT	A max.	A ₁	A ₂	A ₃	b _p	c	D ⁽¹⁾	E ⁽²⁾	e	H _E	L	L _p	Q	v	w	y	z ⁽¹⁾	
mm	1.10	0.15 0.05	0.95 0.80	0.25	0.30 0.19	0.2 0.1	5.1 4.9	4.5 4.3	0.65	6.6 6.2	1.0	0.75 0.50	0.4 0.3	0.2	0.13	0.1	0.40 0.06	8° 0°

Figure 20: TSSOP16

Plastic thin shrink small outline package; 16 leads; body width 4.4 mm

©XEMICS, 2003

All rights reserved. Reproduction in whole or in part is prohibited without the prior written consent of the copyright owner. The information presented in this document does not form part of any quotation or contract, is believed to be accurate and reliable and may be changed without notice. No liability will be accepted by the publisher for any consequence of its use. Publication thereof does not convey nor imply any license under patent or other industrial or intellectual property rights.

XEMICS PRODUCTS ARE NOT DESIGNED, INTENDED, AUTHORIZED OR WARRANTED TO BE SUITABLE FOR USE IN LIFE-SUPPORT APPLICATIONS, DEVICES OR SYSTEMS OR OTHER CRITICAL APPLICATIONS. INCLUSION OF XEMICS PRODUCTS IN SUCH APPLICATIONS IS UNDERSTOOD TO BE UNDERTAKEN SOLELY AT THE CUSTOMER'S OWN RISK.

Should a customer purchase or use XEMICS products for any such unauthorized application, the customer shall indemnify and hold XEMICS and its officers, employees, subsidiaries, affiliates, and distributors harmless against all claims, costs damages and attorney fees which could arise.