

# XE1209EVK Evaluation Kit

## User's Guide

For further information, please contact

**XEMICS SA**  
E mail: [info@xemics.com](mailto:info@xemics.com)  
Web: [www.xemics.com](http://www.xemics.com)

## Introduction

Firstly, many thanks for using XEMICS products. The XE1209 Evaluation kit is a flexible support tool that allows you to extract and evaluate the XE1209 electrical performances with your application environment parameters. All the XE1209 modes and functions behaviors are controlled via user-friendly menu-driven software installed on a WINDOWS based PC. Configuration data and results are entered and read directly via the keyboard/mouse and the PC screen.

For customers who wish to start application designs based on this evaluation kit, detailed descriptions on PCB, component characteristics and layout implementation are also given.

In a typical utilization of the XE1209 Evaluation kit, the minimum measurement tools are recommended:

- WINDOWS based PC (to program the XE1209 behaviors)
- Spectrum analyzer (if one needs to visualize RF signals spectrum i.e. LO, RFOUT,...)
- Oscilloscope to visualize the demodulated data and synchronized clock
- RF generator
- Pattern generator

## Kit Contents

- RF board with XE1209 circuit soldered with components and connectors; the XE1209 EVAL board.
- Interface board ; the PC-XE1209 INTERFACE board
- Inter-board connector
- XE1209 CD ROM
- This present user guide

## Software installation

The application **XE1209** is an executable program. It has been created with the software Labview, which works under Windows 3.x. It enables the configuration of the main characteristics for the XE1209 Low-Power UHF transceiver, via the 3-wire bus.

Click on Setup.exe and then follow the installation instructions on the screen.

**Note :** it is necessary to have PC screen set with 1024\*768 pixels minimum and with small characters, in order to get the software working properly. In addition, <xel209.exe> needs the file <lvdevice.dll>; this file is automatically copied during the unzip operations.

## Hardware Setup

### Connection of the interface board:

The interface is connected with the parallel port of the PC. The cable (not included in the kit) used for connection between the interface board and the PC is a 25pin RS232-C. The 2 boards are interconnected via 10 flat wires cable; one can choose either the K1 or K2 connection on the RF side.

The 2 boards (XE1209 board and the PC-XE1209 interface board) must be both power supplied by a VDD at 2.6V

### How to use the program for the configuration of the XE1209:

Once the program is executed, the main screen shows five different menus that user has then to select.

There are:

- Bits Direct Programming menu
- Features Programming menu
- Frames Sequence menu
- Parallel Port Configuration menu
- Parallel Port Control menu
- 

The 5 menus are shown and described here below:

## Bits Direct Programming Menu:

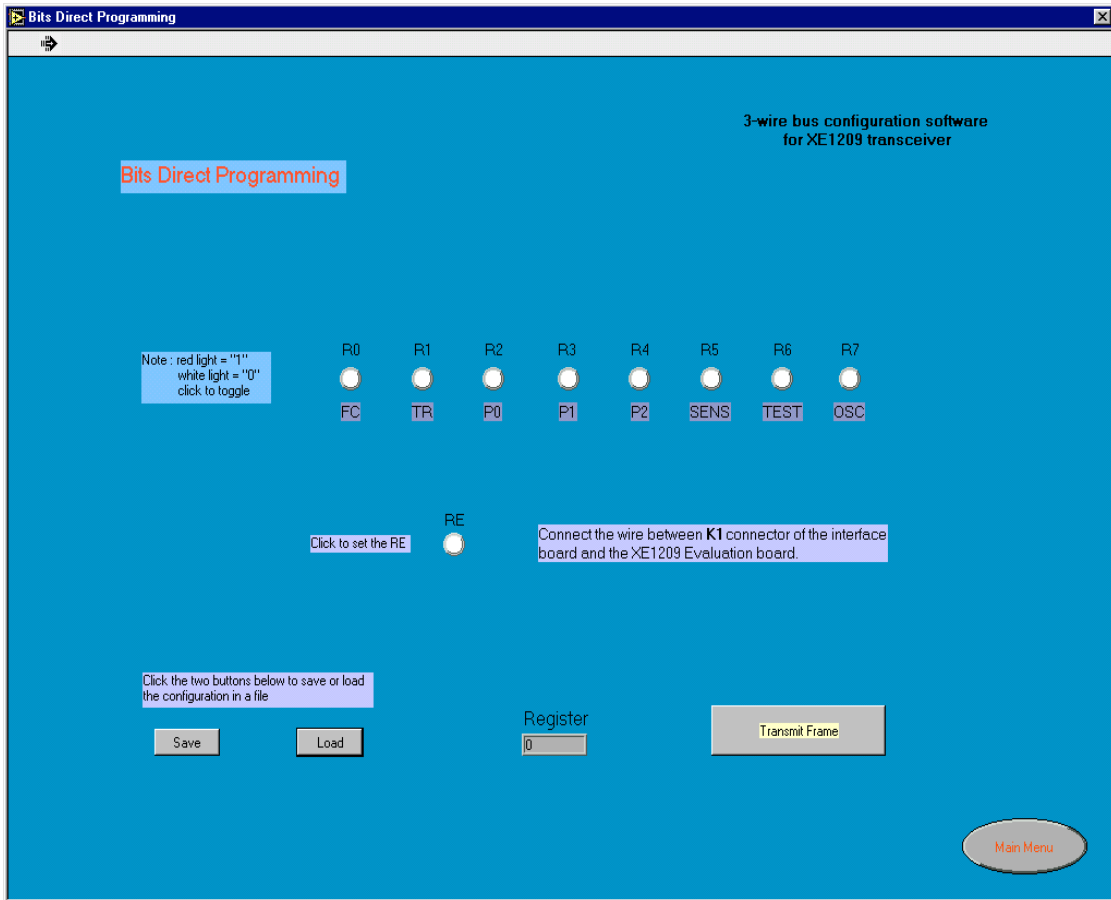

Here, one can program all the different bits of the internal register, via the line SD. Click on the corresponding small circular buttons to select the desired option (Activation at value 1; visible through a red dot). Once all the choice are validated, click on the Save button to store these settings. To activate the operations the “transmit Frame” button must be “pushed”.

## Features Programming Menu

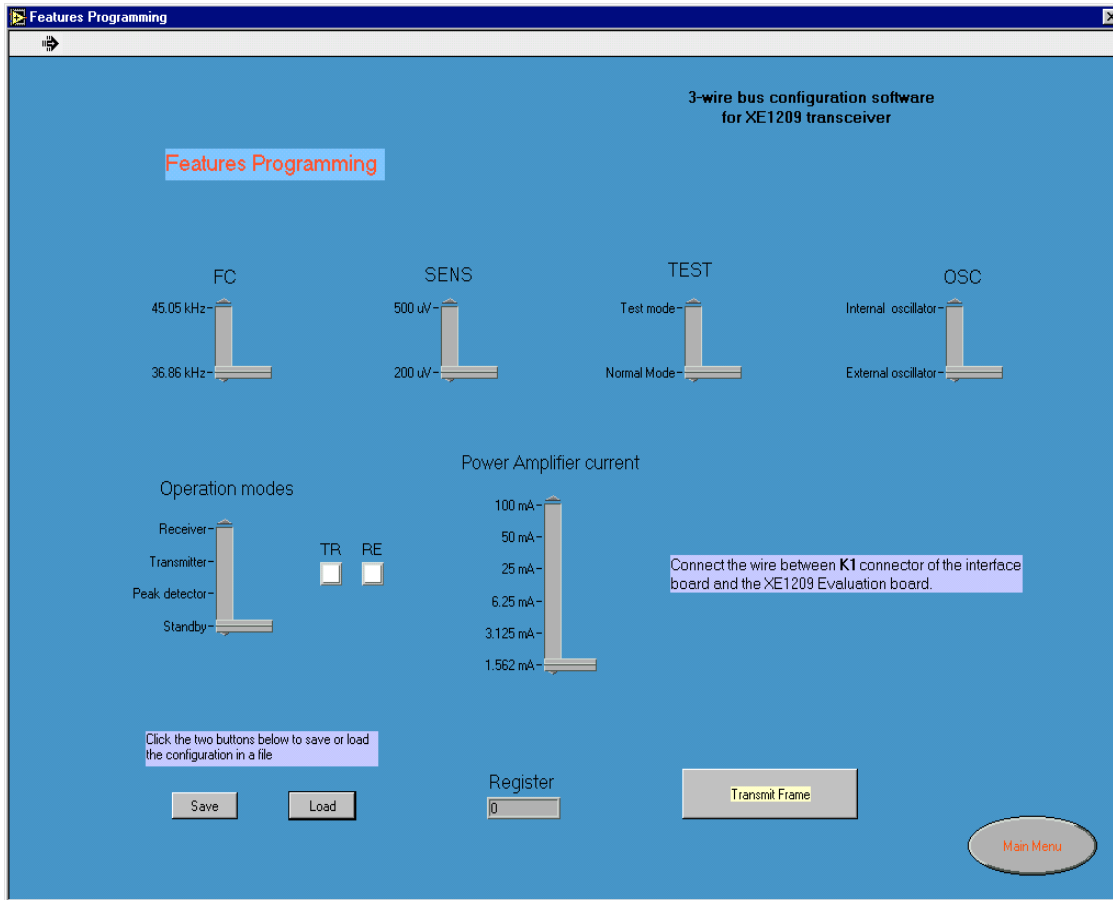

Here, one can program all the different characteristics of the transceiver, as described in the XE1209 data sheet. The user enters the desired features; when all the data have been entered, selections are validated by a click on the Save button. Again, operations are executed after having pushed the “Transmit Frame” button.

The user can program six different characteristics:

- FC: Carrier Frequency
- SENS: Peak detector sensitivity
- TEST: Test or normal mode.
- OSC: Oscillator
- Operation modes
- Power Amplifier current

### Carrier frequency:

The user can choose two different carrier frequencies: 38kHz (18/16 CLK) and 45kHz (22/16 CLK).

Note: The carrier frequency must be chosen accordingly with the antenna matching for a proper transmission.

### Peak detector sensitivity:

The function of the SENS is to detect the presence of a signal at the carrier frequency  $F_c$ . Its output is activated when the amplitude of the input signal exceeds a predefined threshold. In this case the output signal is a square wave at frequency  $F_c/8$ .

### Test or normal mode:

Set to normal mode

**Oscillator:**

For the Internal Oscillator mode, an Xtal (32kHz) is connected between Qin and Qout pins. In this case the oscillator always running.

For the external oscillator mode, the transceiver needs an external clock on Qin pin that can be given for example by a micro-controller. In this case the oscillator can be switch on or switch off via the micro-controller.

**Operation modes**

In standby mode : current consumption = 200nA (Oscillator Off) and 1uA(oscillator On)

Peak detector mode: current consumption 95uA

Transmitter: The data are transmitted via DATA pin (17) and TR bit (Transmission flag) is automatically set to 1 and the bit RE (receiver enable) is set to 0. The current consumption depends of the Power amplifier current.

Receiver: The data are receiver on pin 17 and a synchronized data clock on pin 16. In this mode the bit RE and TR are automatically set to 1. The current consumption is 200uA.

Power amplifier current: The user can select the output power via the current consumption of the power amplifier block.

## Frames Sequence Menu

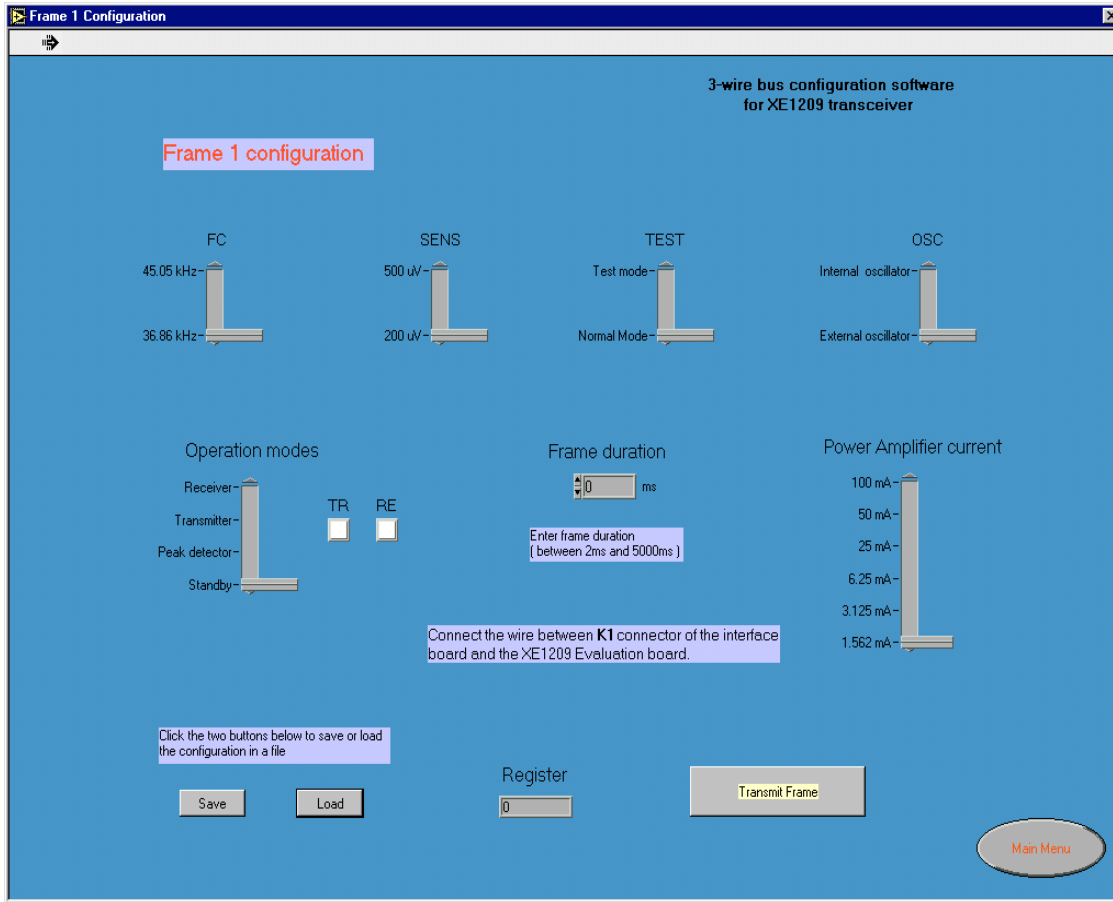

One can send four lift sequences to the transceiver one after the other. The duration between sequences can be changed and set by user (this duration depends also of the Clock speed of the CPU of the PC). The figure that is following shows the possible set-up of one of the Frame Configurations.

## Parallel Port Configuration Menu:

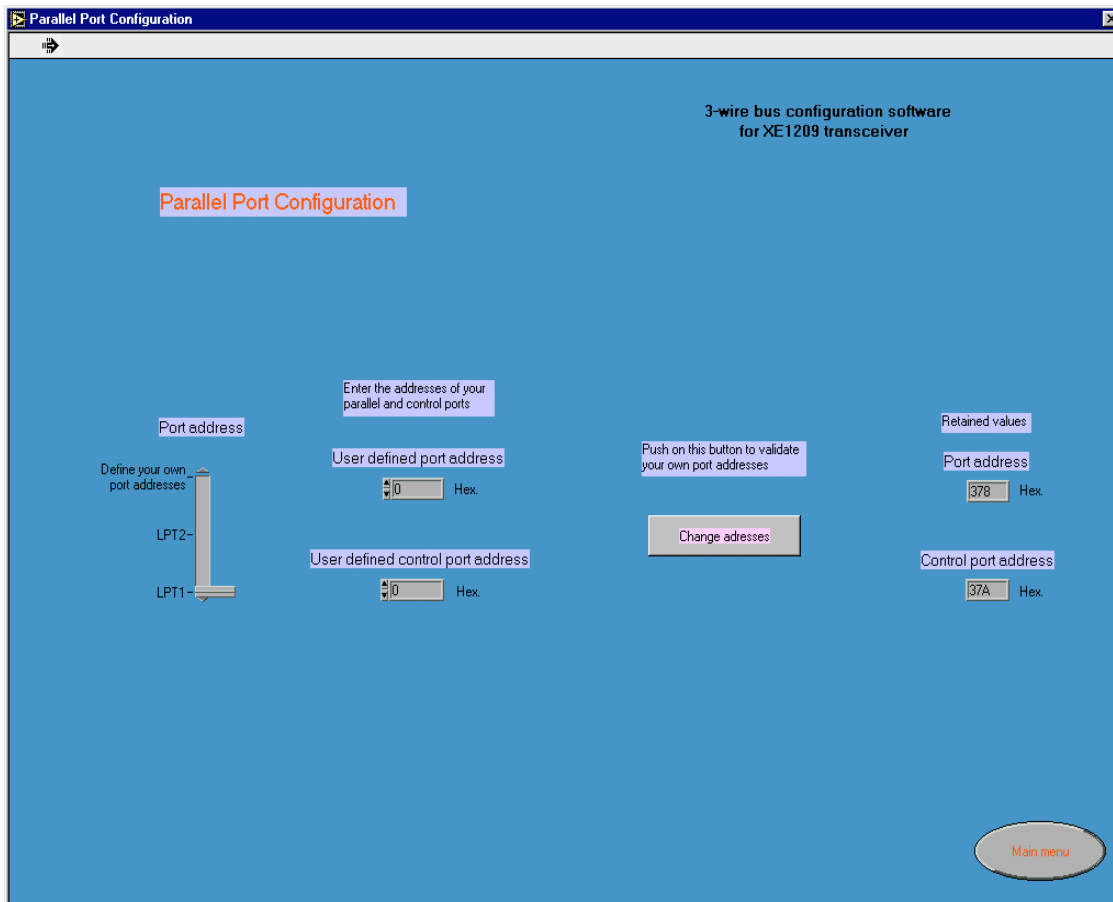

One can choose the parallel port of the PC, send data LPT1 or LPT2, or define own Port Address (in Hex). Click on the Validate button to activate the new address.

## Parallel Port Control Menu:

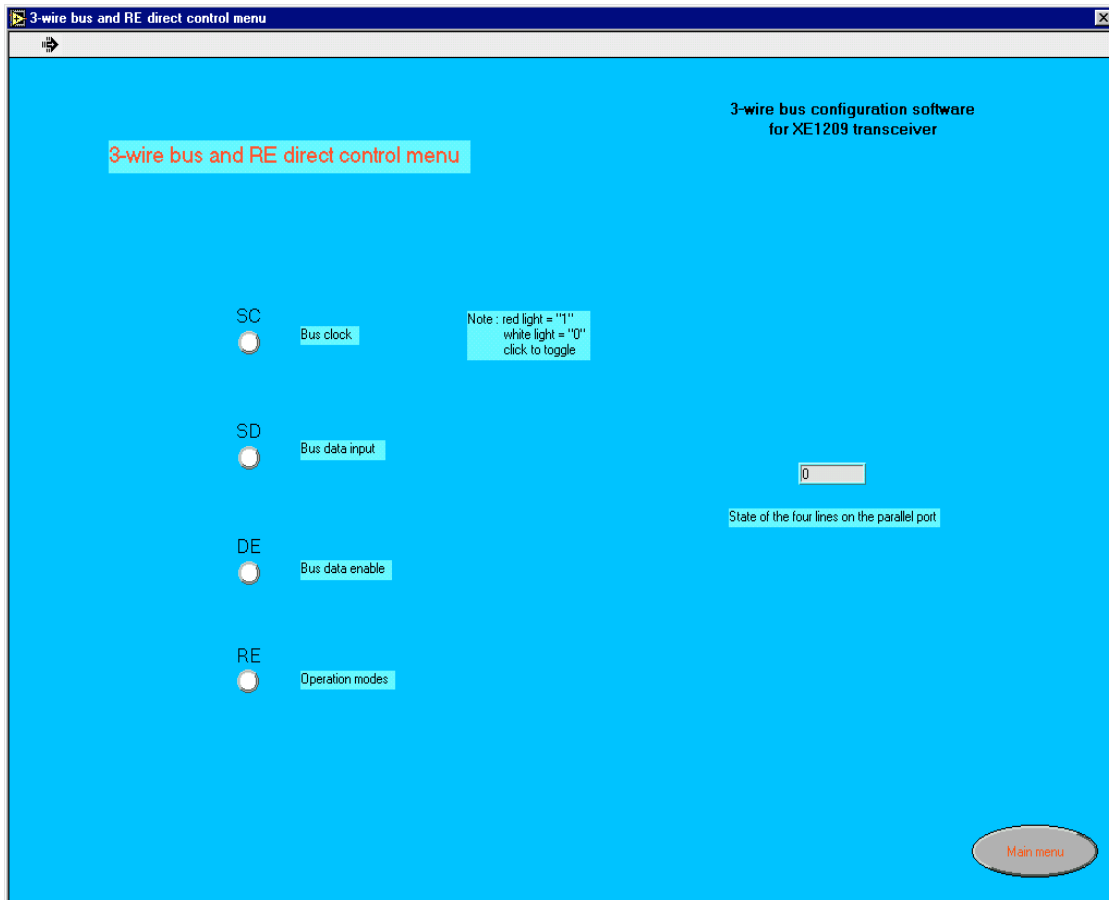

One can control the static level of the 3-wires bus, as well as the line Operation Mode. Click on the radio buttons to activate the following parameters:

- Bus Clock
- Bus Data Input
- Bus Data Enable
- Operation mode
  - "1" = Receiver mode
  - "0" = Transmitter mode

## Parallel Port address Selection

Every parallel port has an address identified in the PC. Correct address selection is required prior to sending data on the right parallel port. This address must be known in advance; it can be found in the PC documentation or through the BIOS program during any PC initialization phase.

Once known, the parallel port address can be entered from the Labview program via the menu

< Parallel Port Configuration >.

There are three different practical cases (linked to the user PC hardware) :

1. The PC has only one parallel port named LPT1 and is addressed by :

### **0378 Hex**

and the control port is defined by :

### **037A Hex. ( "default mode" in the program )**

2. The PC has two parallel ports and LPT1 is already used (usually a printer). One can use the second parallel port named LPT2 and it is addressed by :

### **0278 Hex**

and its control port is defined by :

### **027A Hex**

3. The PC has a special address for its parallel port. In this case, enter just its corresponding address in the program.

### Evaluation kit XE1209: Schematic

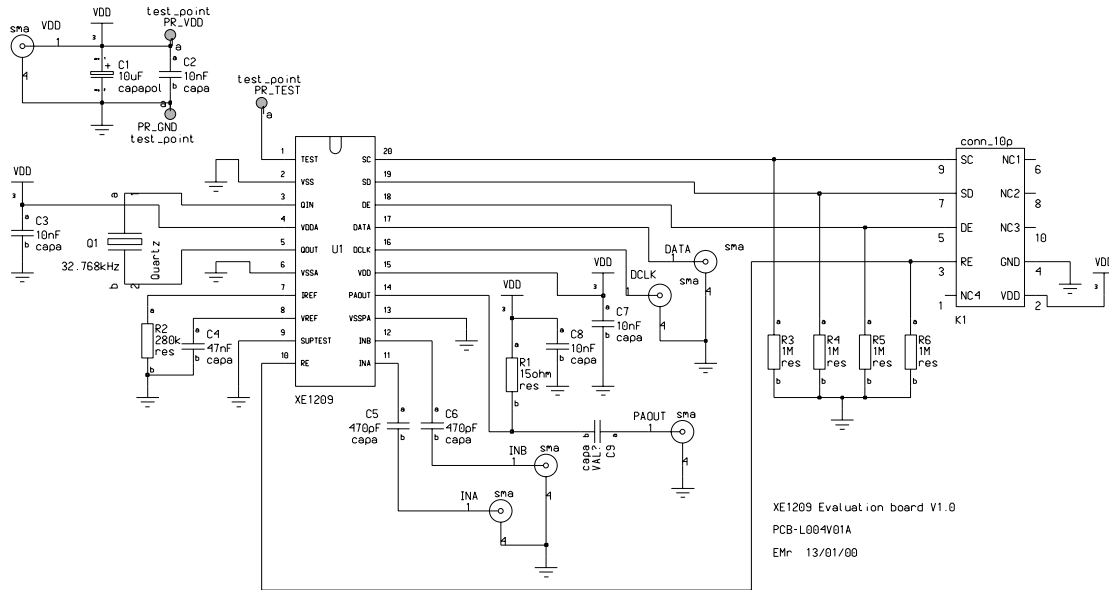

Figure 1 : Electrical schematic of the XE1209 Evaluation board

### Evaluation kit XE1209: Bill of Material

Xe1209 Board	Components	Value	Qty
U1	Transceiver circuit	NAP	1
Xtal	Xtal quartz	32kHz	1
CVdd1	Decoupling Vdd	10uF	1
CVdd2	Decoupling Vdd	100nF	1
C5, C6	Coupling Rfin	470pF	2
C7, C8, C9	Decoupling Vdd	100nF	3
Cvref	Decoupling Vref	47nF	1
Riref	Iref	280k	1
R2	Load PAout	15	1
Conn_10p	Connector 10 pins		1
VDD,INA,INB, PAOUT, DATA, DCLK	SMC connector		6

## Annex Layout of the XE1209

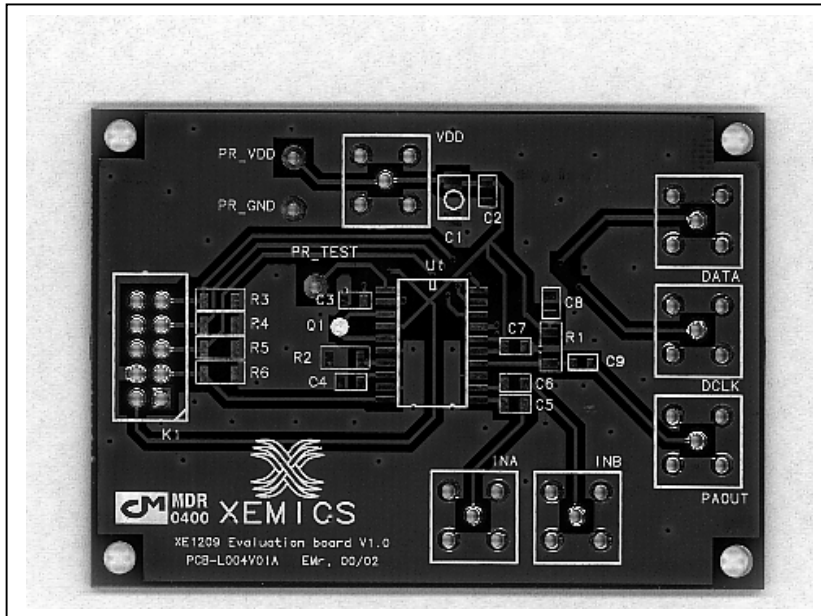

Figure 2 : Top view of the XE1209 Evaluation board

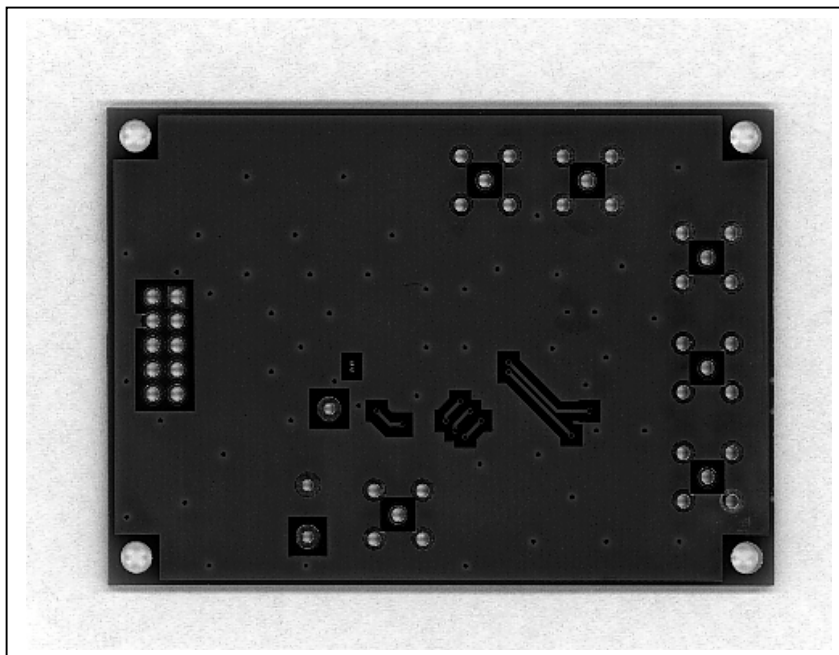

Figure 3: Bottom view of the XE1209 Evaluation board

©XEMICS, 2001

All rights reserved. Reproduction in whole or in part is prohibited without the prior written consent of the copyright owner. The information presented in this document does not form part of any quotation or contract, nor is believed to be accurate and reliable and may be changed without notice. The publisher for any consequence of its use will accept no liability. Publication thereof does not convey nor imply any license under patent or other industrial or intellectual property rights.