

---

# AN1201A.01

## Application Note

---

### *2.4 GHz RF/IF converter for the XE1201A single chip transceiver*

Author : Gael Goron  
For further information, please contact

**XEMICS SA**  
E mail: [info@xemics.com](mailto:info@xemics.com)  
Web: [www.xemics.com](http://www.xemics.com)

## Introduction

This application note describes a method for using the XE1201A on the World Wide Free 2.4GHz band. The approach is based on the insertion of an RF/IF conversion stage. The XE1201A is a half-duplex FSK single chip transceiver for operation in the 433MHz ISM band and in the 390-470MHz band. The modulation used is the Continuous Phase 2 level Frequency Shift Keying (CPFSK).

The frequency adaptation between 2.4GHz and Intermediate Frequency (IF) is realized via an RF/IF Converter. This IF needs to be chosen into the 390-470 MHz band for a proper operation of the XE1201A. The typical 2.4GHz application is made with two blocks, the RF/IF converter and the XE1201A transceiver.

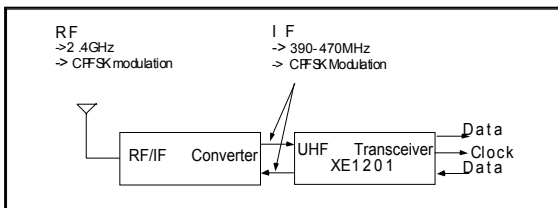

Figure 1: Typical 2.4GHz Application block using the XE1201A

## General Description

The principle is to shift the 2.4GHz (RF carrier frequency) to an intermediate frequency (IF) and vice-versa with IF value inside the XE1201A operation band (figure 2).

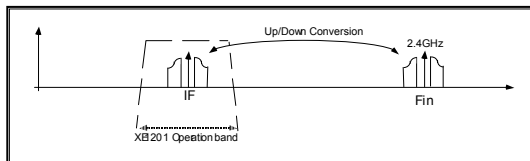

Figure 2: Principle of RF/IF converter

A mixer (figure 3) is used to realize this conversion. This function generates two different frequencies:

- $F_{out1} = F_{LO} + F_{in}$  (eg1)
- $F_{out2} = F_{LO} - F_{in}$  (eg2)

Where FLO is the Local Oscillator frequency.

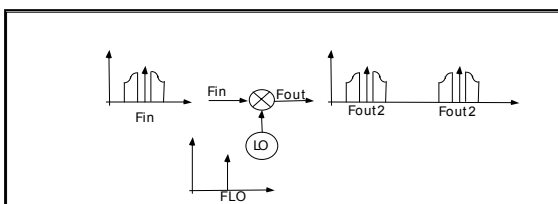

Figure 3: Mixer

The mixer architecture has the advantage of making an Up or Down conversion without circuit modification.

The input frequency (initial carrier frequency) is shifted up/down two frequencies at Fout1 and Fout2.

## Define the local oscillator frequency

According to the equations eg1 and eg2, two different LO frequencies can be defined (FLO1 and FLO2). Moreover, the IF needs to be chosen between 390-470MHz (XE1201A operation band), for example 433MHz (commonly used in Europe). For a down conversion, Fout is equal to the intermediate frequency (IF) plus the input frequency is the carrier frequency (2.4GHz).

$$F_{LO1} = IF - F_{in}$$

$$F_{LO1} = |433\text{MHz} - 2.4\text{GHz}|$$

$$F_{LO1} = 1.967\text{GHz}$$

The figure 4 shows the spectrum utilization and the two possibilities for the LO choice.

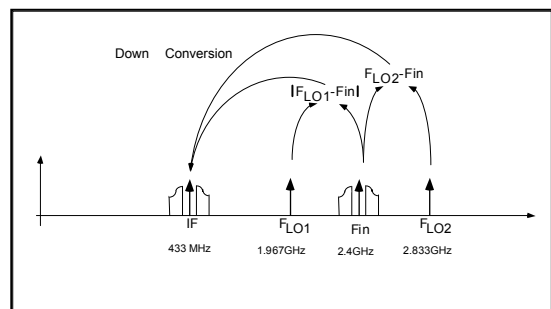

Figure 4: Spectrum utilization.

The LO frequency retained is 1.967GHz. Since it is easier to generate a local oscillator at 1.967GHz than 2.833GHz (FLO2). The output mixer result (Figure 5) consists of two spectra, one is the sum result (Fout1) and the other is the minus result (Fout2).

Therefore, the carrier frequency 2.4GHz is shifted up or down to 433MHz due to the 1.967GHz of the Local Oscillator. And the XE1201A can operate in its normal range. The frequency Fout1 is easily eliminated via a filter.

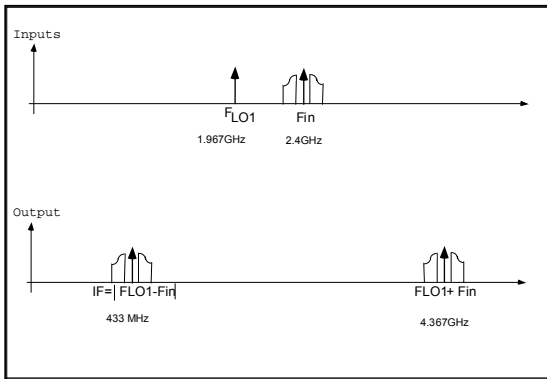

Figure 5: Mixer output

### Image frequency

With this type of architecture and according to the equations (eg1 and eg2) another frequency can be shifted to 433MHz, it is the image frequency (figure 6). This is the parasitic frequency.

$$F_{image} = F_{LO} - IF$$

$$F_{image} = 1.967\text{GHz} - 433\text{MHz}$$

$$F_{image} = 1.534\text{GHz}$$

This frequency (1.534GHz) must be cancelled. A low-cost band pass filter is placed before the input mixer (figure 7). The center frequency is 2.4GHz.

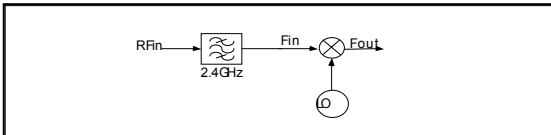

Figure 7: RF Pass-band filter

### Implementation

Real mixers generate various frequencies (in addition to the wanted ones). Their values are given by the following formula:

$$F_{out} = |mF_{LO} \pm nF_{in}|$$

Where m and n are integer (When m=n=1, it is the ideal case described above)

### Up-conversion path (figure 8)

A band pass filter, with a center frequency at 2.4GHz, is required in the transmission path at the mixer output to cancel the spurious products. An optional band-pass filter, centered at IF frequency, can be added for a spurious XE1201A output filtering. The filter utility depends of the application specifications.

Figure 8: Up conversion path

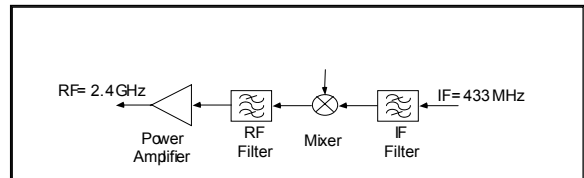

### Down-conversion path (figure 9)

A band pass filter at 2.4GHz is included in the path to cancel the frequency image. The optional band pass filter at 433MHz cancels the spurious resulting of the mixer operation and for a better out of band rejection.

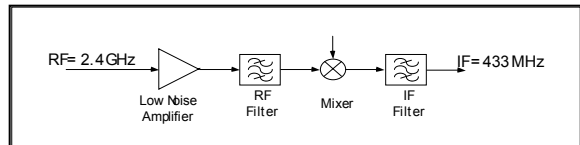

Figure 9: Down conversion path

Moreover, a Low Noise Amplifier is added in the reception path and a Power Amplifier in the transmission path (figure 10).

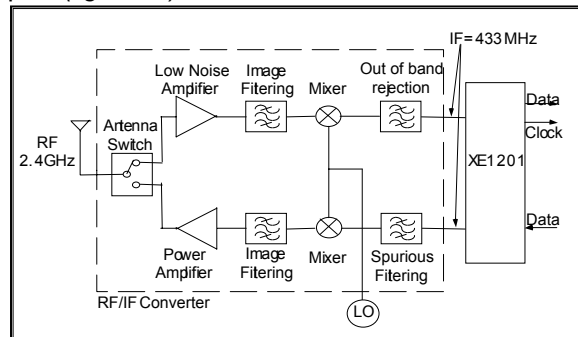

Figure 10: Functional block diagram

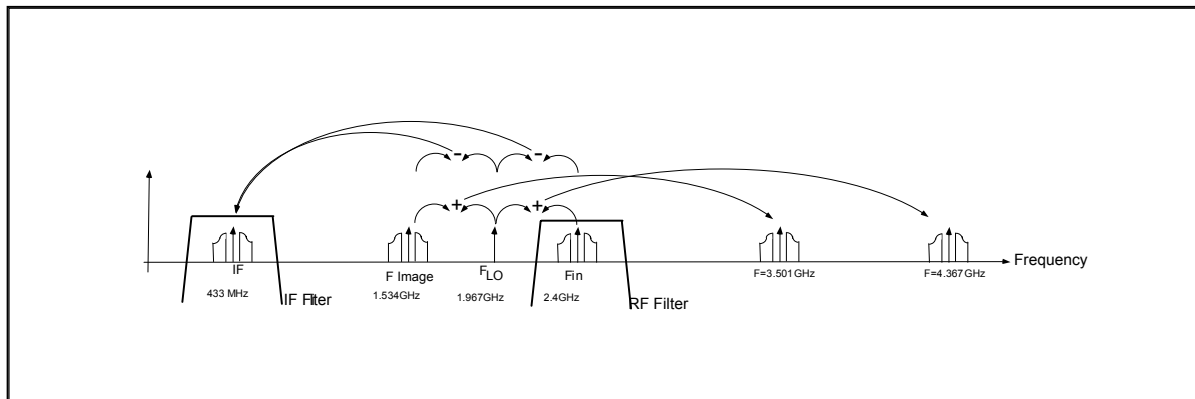

Figure 6: Spectrum of the mixer result with image frequency

## Filters Characteristics

The modulation used is a CPFSK with +/-200KHz for the frequency deviation. A margin for the IF filter bandwidth is required due to the LO drift and filters tolerance. So the IF filter needs to have a bandwidth at -3dB around 500KHz.

For the RF filter, the bandwidth can be large according to the required image frequency rejection (1GHz between the image frequency and the carrier frequency).

## Components Indications

- Single Chip solution => Harris : HFA3624  
(2 mixers + PA + LNA)
- RF Filter => Murata : LFJ30-03B244B084
- IF Filter => "Discrete components"
- Antenna switch => Motorola : MRFIC1801
- PLL => Motorola: MC145202

©XEMICS, 2003

All rights reserved. Reproduction in whole or in part is prohibited without the prior written consent of the copyright owner. The information presented in this document does not form part of any quotation or contract, is believed to be accurate and reliable and may be changed without notice. No liability will be accepted by the publisher for any consequence of its use. Publication thereof does not convey nor imply any license under patent or other industrial or intellectual property rights.